

Mobrey MSP 2 wire 24V loop powered

Ultrasonic level transmitters



mobrey

EMERSON[™]
Process Management

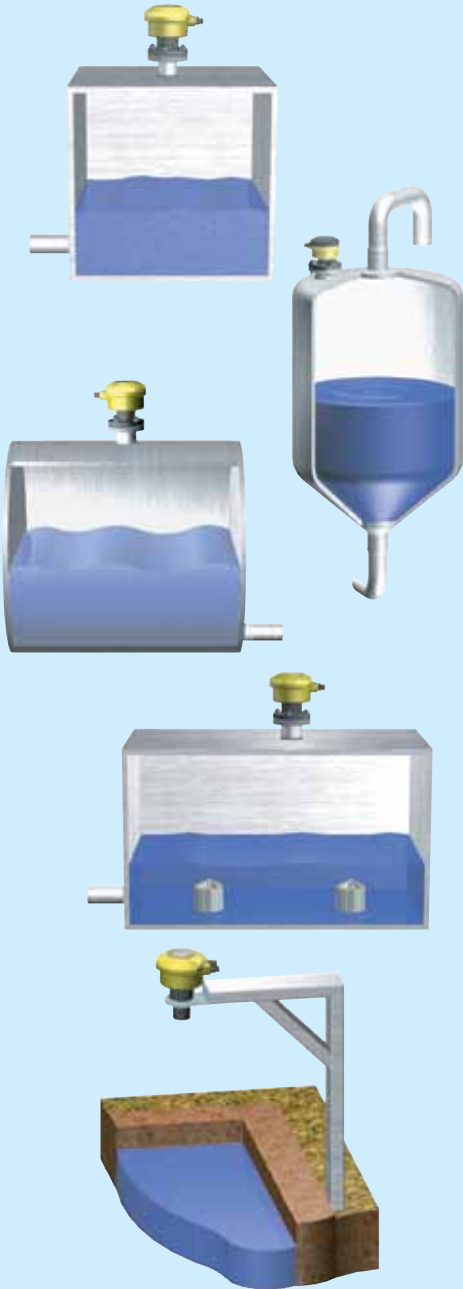

Features

- 2 Wire 24V dc loop powered
- Operating ranges up to 11m / 36ft
- Measures liquid height, distance to liquid, volume or flow in open channels
- Simple push button calibration
- Built-in LCD display
- Automatic temperature compensation

Advantages

- Eliminates problems experienced with contacting instrumentation
- Eliminates costly installation and mounting
- Simplified set-up and operation
- Minimal maintenance once installed

Benefits

- Lost cost of installation
- Low cost of commissioning
- Minimal maintenance costs
- Process downtime minimised

MSP Advanced ultrasonics

This new family of ultrasonic non-contacting liquid level transmitters is the latest generation of Mobrey level measurement instrumentation.

Proven in thousands of applications in many industries, state of the art electronics coupled with time proven ultrasonic transducer technology has resulted in an easy to use instrument with the high reliability and quality readings usually associated with more expensive products.

Choose the MSP422 entry level model for simple level measurement, or select the MSP400RH with 2 integral relays to add local control functionality. For hazardous areas, the MSP900GH is intrinsically safe certified.

These transmitters pack even more features into their stylish enclosures - see the product outlines on the next page to help you choose the right model for your application.

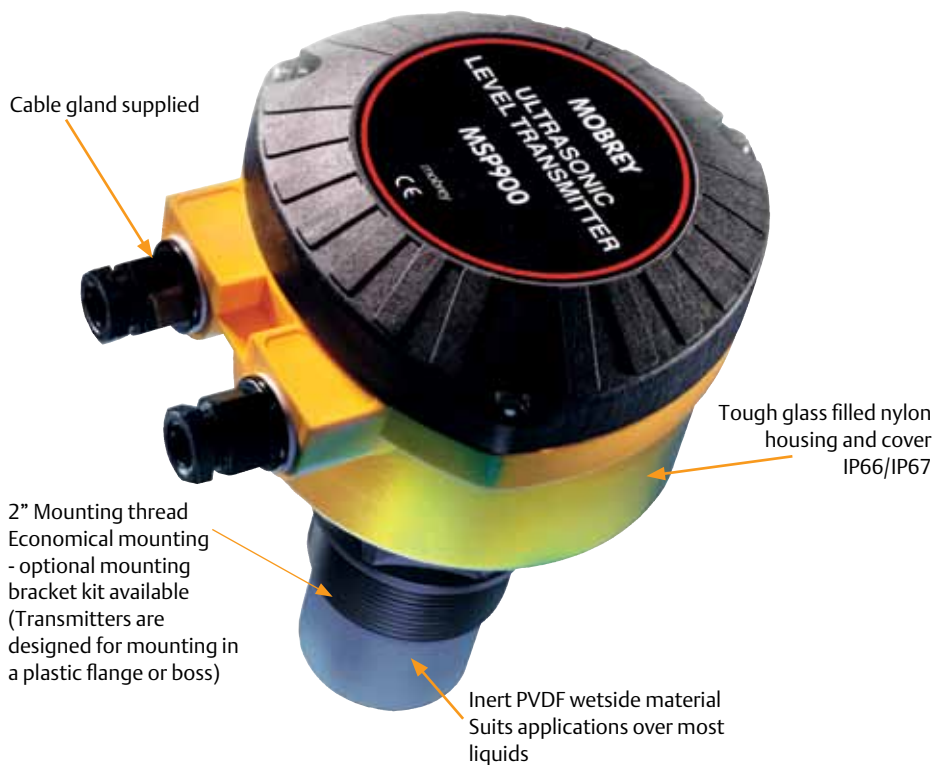

Easy to use local menu programming

Once installed using the 2" thread, either directly to the vessel or on a suitable bracket above the liquid surface, 3 internal buttons are used to programme the transmitter with the tank depth and the range for the 4-20mA output.

A built-in LCD display under the cover is provided to aid setting up.

The user navigates through an intuitive menu, entering data as prompted by the transmitter. Intelligent software ensures only data specific to the chosen application is requested, minimising programming time.

Programming using a PC or HART® compatible communicator

The MSP400RH and MSP900GH are HART compatible and may be accessed remotely on the 2 wire loop. Using a HART universal communicator such as the Rosemount® 375, the user can access all set-up and diagnostic parameters for interrogation or change.

Alternatively, universal HART programming tools loaded with the transmitter Device Description (from the HART foundation CD) may be used. If the DD is not loaded, the user can still access and change some parameters using universal and some common practice commands.

Operation

Ultrasonic pulses transmitted from the transmitter face are reflected from the surface of the liquid and are received back by the same transmitter.

Measurement of the time delay between the transmit and the receive signals enables the microprocessor controlled electronics to calculate distance to the liquid level.

Once the transmitter is programmed with the bottom reference of the application - usually the bottom of the tank - the liquid depth is calculated. The microprocessor controls the loop current to give a 4-20mA output signal proportional to the level, with the liquid level reading also available on the LCD display inside the enclosure.

All transmitters have integral temperature compensation to maintain accuracy across the operating temperature range.

Choosing the right model

Each of the three models in the MSP range provide features which make them suitable for specific duties, as shown below:

Simple level measurement		
Model	8m / 26ft range	MSP422
	11m / 36ft range	MSP400RH
Level measurement and local relays		
Model	11m / 36ft range	MSP400RH
Level measurement in a hazardous area		
Model	11m / 36ft range	MSP900GH
Flow or volume measurement		
Model	Safe area	MSP400RH
	Hazardous area	MSP900GH

Technical specifications

	MSP422 	MSP400RH
Duty	Level	Level, distance, volume, flow
Measuring range	0.3 to 8.0m / 1.0ft to 26ft	0.3 to 11.0m / 1ft to 36ft
Process temperature	-20°C to +70°C / -4°F to +158°F	-30°C to +70°C / -22°F to +158°F
Power supply	2 wire, 24V dc loop powered	2 wire, 24V dc, loop powered
Output	4-20mA	4-20mA
Digital communications	None	HART
Integral relays	None	2 x SPST 1A @ 24V dc
External temperature probe option	None, integral only	Accepts MSP-RTP input (see accessories)
Certification	Safe area use only FM General electrical use	Safe area use only FM General electrical use
Ordering information	MSP422-B28: 2" BSPT mounting MSP422-N28: 2" NPT mounting	MSP400RH-B28: 2" BSPT mounting MSP400RH-N28: 2" NPT mounting

MSP422

Entry level



The MSP422 entry level transmitter is designed specifically for use in the many industrial applications where economical liquid level measurement with a 4-20mA output proportional to level is required.

The tough weatherproof nylon body and corrosion resistant PVDF wetside make the MSP422 suitable for a wide range of applications.

Installation is simple and economic using the 2" thread. (Mounting bracket available as an optional extra.)

Programming is achieved in under two minutes with minimal data entry required.

Applications

- Filter bed level
- Storage tank levels
- Effluent pits
- Reservoir level

MSP400RH

The MSP400 level transmitter offers all the features of the entry level MSP422 with the addition of HART digital communications and two integral relays to provide local control functionality over an increased range of 11m / 36ft. The relays are signal relays designed to operate in alarm or fault mode.

The user may also choose to configure the MSP400 to calculate volume in a vessel or flow in an open channel according to several pre-programmed laws:-

- Horizontal cylinder or sphere
- Rectangular flumes and weirs
- "V" notch weirs
- Parshall flumes
- Manning formula

Alternatively, a 10 point DIY curve is available (use HART programmer for this mode).

Applications

- Inventory control
- Buffer tanks
- Open channel flow

Integral relays



MSP900GH

Intrinsically Safe



The MSP900GH level transmitter is intrinsically safe certified for use in hazardous areas. Power must be supplied through a suitable I.S. barrier. HART digital communications are also provided.

With a PVDF wetside, the MSP900GH can be used in most hazardous and corrosive applications.

The MSP900GH may be used to measure distance, level or calculate volume or flow in an open channel according to several pre-programmed laws:-

- Horizontal cylinder or sphere
- Rectangular flumes and weirs
- "V" notch weirs
- Parshall flumes
- Manning formula

Alternatively, a 10 point DIY curve is available (use HART programmer for this mode).

Applications

- Inventory control
- Buffer tanks
- Open channel flow

Accessories

MSP-RTP remote temperature probe

The MSP-RTP probe is designed to be used with the MSP400RH and MSP900GH transmitters in applications where fast ullage temperature changes or unrepresentative transmitter temperatures are a problem.

The probe is simply installed in the vessel ullage space or in a shaded area of an open channel and wired back to the transmitter using the 5m / 16ft of cable provided. When the MSP-RTP is connected the integral temperature probe is automatically over-ridden.

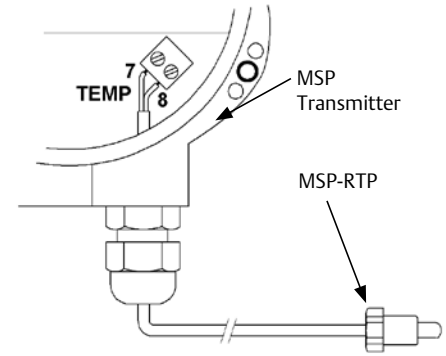

Details in data sheet IP2036

MSP-BRK mounting bracket

316 Stainless Steel angle bracket with UPVC mounting boss to facilitate transmitter installation.

MSP-BRK2: 2" BSPT fitting

MSP-BRK3: 2" NPT fitting

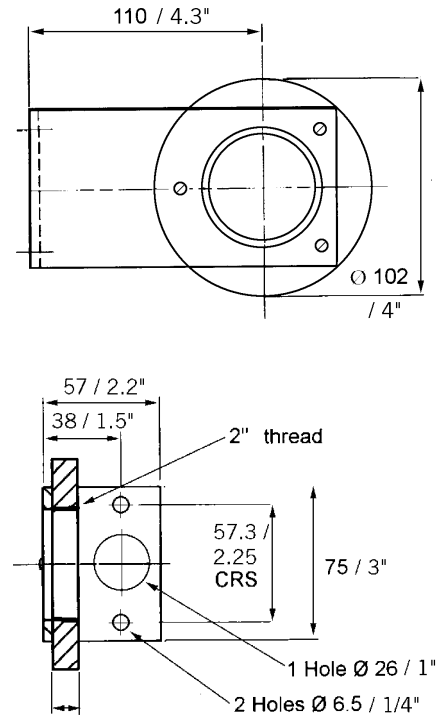

MSP900GH	Ex
Level, distance, volume, flow	
0.3 to 11.0m / 1ft to 36ft	
-30°C to +70°C / -22°F to +158°F	
2 wire, 24V dc loop powered	
4-20mA	
HART	
None	
Accepts MSP-RTP input (see accessories)	
ATEX II 1 G Ex ia IIC T6	
MSP900GH-A: 2" BSPT mounting ATEX	

ADDITIONAL TECHNICAL DATA		
Ambient temperature	MSP400/900:	-40°C to +60°C / -40°F to +140°F
	MSP422:	-20°C to +70°C / -4°F to +158°F
Operating pressure		-0.25b to +3.0b / -3.6psi to +43psi
Accuracy*	MSP400/900:	< 1.0m / 3.3ft; +/-2.5mm / 0.1"
		> 1.0m / 3.3ft; +/-0.25% of measured range
	MSP422:	< 1.0m / 3.3ft; +/-5mm / 0.2"
		> 1.0m / 3.3ft; +/-0.5% of measured range
Resolution		< 1mm / 1/16"
Weatherproof rating		IP66/67 / NEMA Type 4
Materials of construction		Dryside: Glass filled nylon; Wetside: PVDF
Weight		850g / 2lb
Electromagnetic compatibility		EN61326 Class B

* Under reference conditions 20°C, 1013 mbar, RH 50% relative humidity

Mobrey universal control units: ideal for programming and control of the MSP range of transmitters



The MCU900 series of wall and panel mounting control units provide comprehensive control functionality for any 4-20mA or HART compatible transmitter. A back-lit display gives clear visual indication of the measured value and status of all inputs and outputs. Mounted in a non-hazardous area, the

mains powered MCU900 provides a protected 24V dc power supply to the transmitter, which may be installed in a hazardous area. 5 relays are provided and are fully field programmable to perform a wide variety of control, fault indication or alarm duties.

Control unit features and application

- Tough weatherproof wall mount enclosure for internal or external mounting
Panel mount units require just 165mm / 6.5" clearance behind the panel
- Accepts any 4-20mA or HART compatible input, allowing standardisation of control units display
- Supports two voltage free contact closure inputs, allowing override of control functions on external triggers
- Pre-programmed tank shapes, flow algorithms and pump control routines simplify configuration
A 20 point DIY look-up table is provided for non-standard applications
- Real time clock allows energy saving routines and pump efficiency calculations
- 5 voltage free SPDT relays for alarm and control duties
- 4-20mA 12 bit isolated current output proportional to calculated value
- Datalogging up to 7000 events

Details in data sheet IP2031

Mobrey sump transmitter: factory sealed for wetwell and open channel flow applications



The MSP900SH/FH is a sealed 4-20mA loop powered level transmitter specifically designed for use in waste water and effluent treatment plant on aqueous applications.

Certified Intrinsically Safe for use in Zone 0 areas, the rugged UPVC transmitter is factory fitted with up to 50m / 165ft of two core cable for simple low cost installation in sumps, wet-wells and over open channel flow structures. The MSP900SH can be connected directly to a plant control system or used with a Mobrey MCU900 Control unit.

- 4-20mA output proportional to measured or calculated value.
- Factory sealed IP68 / Type 6P for use in wet-wells and sumps up to 12m / 39ft deep.
Option of submersion shield

to protect transmitter face from contamination if well is subject to flooding.

- Rugged all UPVC construction ideal for application on exposed sites such as reservoirs, rivers or remote works.
- Supplied complete with 316SS mounting bracket and 1" lock nut to facilitate fast and low cost installation using either rigid or suspension mounting methods.
- MCERTS version available for certified flow systems when used with MCU900 control units

Details in data sheet IP203



Wiring diagram

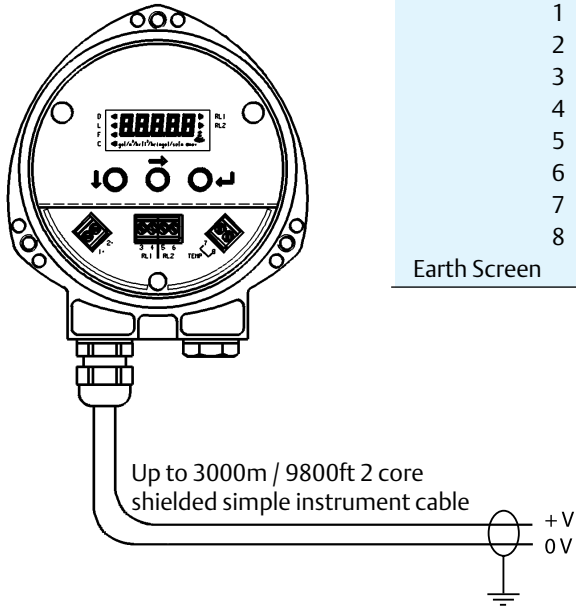

Terminal	
1	: +24V dc
2	: 0V dc
3	: RL1 (SPST)
4	: RL1 (SPST)
5	: RL2 (SPST)
6	: RL2 (SPST)
7	: MSP-RTP temperature probe (if used)
8	: MSP-RTP temperature probe (if used)
Earth Screen	: Connect to a standard earth in the control room

MSP400 only

	Nominal	Range	I.S. Limits
MSP422	24V dc	12-30V dc	n/a
MSP400	24V dc	12-40V dc	n/a
MSP900*	24V dc	12-40V dc	12-30V dc

All models Min. voltage required at terminals:-
12V dc at 21 mA loop current

* Power must be supplied through a suitable I.S. barrier or from MCU900

Dimensional details

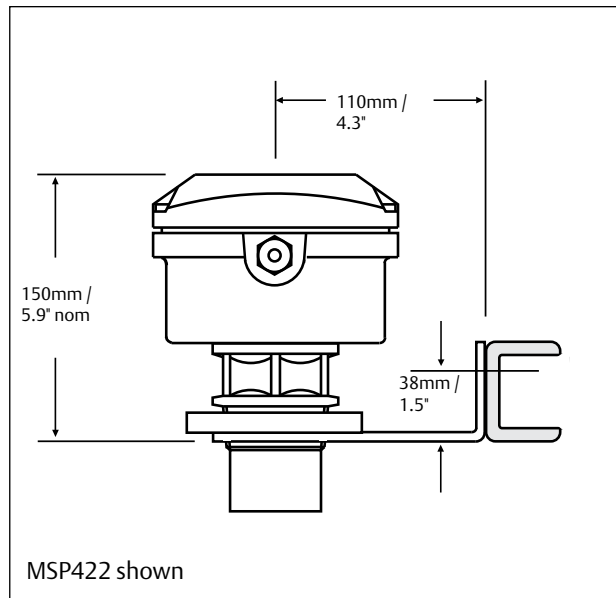
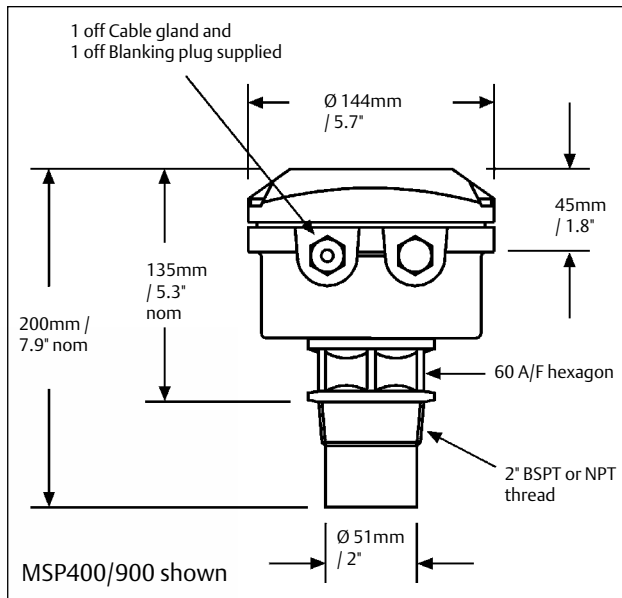

Note: Transmitters are not suitable for mounting in 2" NB pipe. A minimum of 3" NB is required.
Use a plastic flange if mounting onto a tank or standpipe.

The Emerson logo is a trade mark and service mark of Emerson Electric Co.
Mobrey is a registered trademark of Mobrey Ltd.

All other marks are the property of their respective owners

We reserve the right to modify or improve the designs or specifications of product and services at any time without notice.

International:

Emerson Process Management Mobrey Measurement

158 Edinburgh Avenue, Slough,
Berks UK SL1 4UE
T +44 (0)1753 756600
F +44 (0)1753 823589
www.mobrey.com

Americas:

Emerson Process Management Rosemount Inc.

8200 Market Boulevard
Chanhassen, MN USA 55317
T (US) (800) 999-9307
T (International) 952) 906-8888
F (952) 949-7001

