

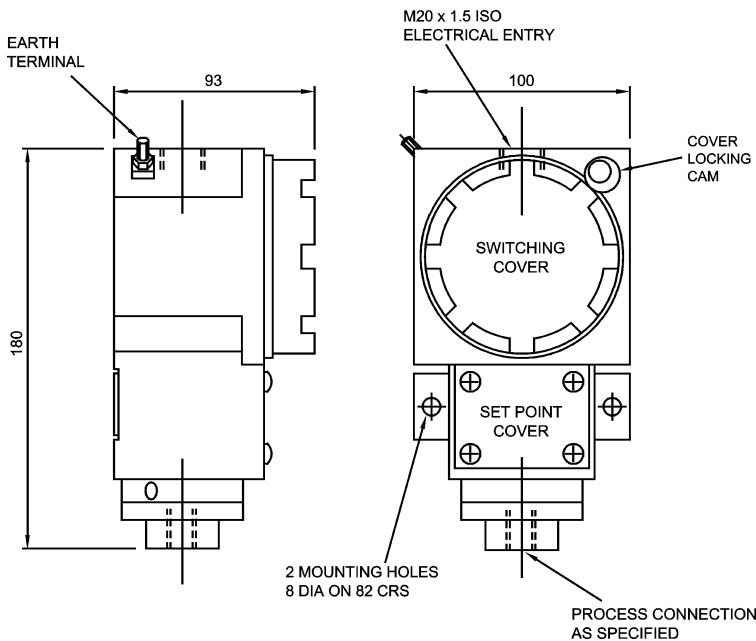

# PRESSURE & DP SWITCHES

SERIES 700

FOR POTENTIALLY EXPLOSIVE ATMOSPHERES



TYPICAL SERIES 700 DIMENSIONED OUTLINE

MANUFACTURED IN THE U.K.

The Series 700 Pressure and Differential Pressure switches offer accurate, reliable switching in a robust cast enclosure.

- **Exd, ExnC, ExtD, Exia, I.S.**
- **RANGES FROM 16 mBAR TO 600 BAR**
- **HIGH OVERLOAD RATINGS**
- **SIMPLE MAINTENANCE**
- **SAFETY VENT RING**

These switches provide excellent repeatability and long in-service life, under both continuous cycling and overload conditions, due to the mechanical restriction of diaphragm travel.

A standard feature of the design is the inclusion of a venting and isolation chamber which (in the unlikely event of the process diaphragm failure) will prevent the process entering the switching enclosure.

The setpoint of the switch is adjusted by means of a capstan head screw, located within the lower section of the enclosure. This enables adjustment to be made even when energised, as it does not violate the flameproof integrity of the enclosure.

With over 50 pressure and DP ranges and a wide selection of output switches, diaphragm and pressure chamber materials, and process connections (including flanges), Series 700 switches meet the requirements of a wide range of applications. In addition HNL can offer many non-standard options (see back page for details) or customise this product to meet your unique requirements. HNL's Series 700 switches can provide many years of maintenance free operation. All models are serviceable and spares, including diaphragm kits and output switch kits are readily available. Drawings and technical data sheets are supplied as standard.

Our extensive stockholding of components and the modular design allows this product to be supplied rapidly to meet customers delivery requirements.

### **Exd SWITCHES (Cert: Baseefa07ATEX0055X)**

Enclosures are certified Exd IIC T4/T5/T6 to EN 60079-0 & EN 60079-1.

### **ExnC & ExtD SWITCHES (Cert: HNL07ATEX0001X)**

Enclosures are certified ExnC IIC T4/T5/T6 & ExtD A22 IP66 100°C to EN 60079-0, EN60079-15, EN 61241-0 & EN 61241-1.

### **Exia SWITCHES (Cert: Baseefa06ATEX0231X)**

Enclosures are certified Exia IIC T5/T6 to EN 60079-0 & EN 50020.

### **I.S. COMPATIBLE**

Series 700 switches are classified as simple apparatus, allowing use in an I.S. circuit without individual certification.

### **QUALITY ASSURANCE**

Designed and manufactured by HNL in accordance with BS EN ISO 9001:2000.





# SERIES 700 PRESSURE & DP SWITCHES SPECIFICATIONS & CODING

<b>PRESSURE RANGES</b>											
<b>SETPOINT RANGES</b>					<b>DIAPHRAGM MATERIAL</b>			<b>CHAMBER PROOF RATING (BAR)</b>			<b>TYPICAL DIMENSIONS (CENTRELINE VERTICAL) H x W x D</b>
<b>RANGE CODE</b>	<b>MIN</b>	<b>MAX</b>	<b>UNITS</b>	<b>% RESET</b>	<b>1</b>	<b>2</b>	<b>7</b>	<b>ALUM.</b>	<b>ST.ST.</b>	<b>HAST.C</b>	
					<b>1</b>	<b>2</b>	<b>7</b>	<b>1</b>	<b>5</b>	<b>7</b>	
714 PZ	-8	8	mBar	2	●	●	-	-	0.5	-	250 x 300 x 316
715 PZ	-15	15			●	●	-	-	0.5	-	
724 PZ	-25	25	mBar	2	●	●	●	2	2	■	227 x 185 x 195
725 PZ	-50	50			●	●	●	2	2	■	
734 PZ	-125	125	mBar	2	●	●	●	10	10	■	220 x 108 x 122
735 PZ	-250	250			●	●	●	10	10	■	
736 PZ	-500	500			●	●	●	10	10	■	
744 PZ	-0.6	0.6	Bar	2	●	●	●	30	30	■	195 x 100 x 93
745 PZ	-1	1.4			●	●	●	30	30	■	
746 PZ	-1	6.0			●	●	●	30	30	■	
734 P	25	250	mBar	2	●	●	●	10	10	■	220 x 108 x 122
735 P	50	500			●	●	●	10	10	■	
736 P	100	1200			●	●	●	10	10	■	
737 P	300	3500			●	●	●	10	10	■	
744 P	0.1	1.4	Bar	2	●	●	●	30	30	30	180 x 100 x 93 (see dimensioned outline on front page)
745 P	0.2	3.0			●	●	●	30	30	30	
746 P	0.7	7.0			●	●	●	30	30	30	
74B P	1	10			●	●	●	30	30	30	
747 P	2	21			●	●	●	35	35	35	
754 P	1.2	12	Bar	3	-	●	●	-	250	250	190 x 100 x 93
755 P	3	30			-	●	●	-	250	250	
756 P	7	70			-	●	●	-	250	250	
757 P	20	210			-	●	●	-	350	350	
758 P	60	600			-	-	●	-	1000	1000	
<b>DIFFERENTIAL PRESSURE RANGES</b>											
714 DPZ	-8	8	mBar	2.5	●	●	-	-	0.5	-	260 x 300 x 316
715 DPZ	-15	15			●	●	-	-	0.5	-	
724 DPZ	-25	25	mBar	2.5	●	●	●	2	2	■	263 x 185 x 195
725 DPZ	-50	50			●	●	●	2	2	■	
734 DPZ	-125	125	mBar	2.5	●	●	●	10	10	-	265 x 108 x 122
735 DPZ	-250	250			●	●	●	10	10	-	
734 DPZM	-100	100	mBar	3	-	-	●	-	300	-	284 x 104 x 122
735 DPZM	-200	200			-	-	●	-	300	-	
736 DPZM	-400	400			-	-	●	-	300	-	
744 DPZ	-0.9	0.9	Bar	3	●	●	●	-	30	-	233 x 100 x 93
745 DPZ	-1	2			●	●	●	-	30	-	
734 DP	25	250	mBar	2.5	●	●	●	10	10	■	265 x 108 x 122
735 DP	50	500			●	●	●	10	10	■	
736 DP	100	1200			●	●	●	10	10	■	
737 DP	300	3500			●	●	●	10	10	■	
734 DPM	20	200	mBar	3	-	-	●	-	300	-	284 x 104 x 122
735 DPM	40	400			-	-	●	-	300	-	
736 DPM	100	1000			-	-	●	-	300	-	
737 DPM	300	3000			-	-	●	-	300	-	
744 DP	0.2	2	Bar	2.5	●	●	●	30	30	30	233 x 100 x 93
745 DP	0.4	4			●	●	●	30	30	30	
746 DP	1	10			●	●	●	30	30	30	
747 DP	2	21			●	●	●	35	35	35	
746 DPM	0.7	7	Bar	3	-	-	●	-	300	-	284 x 104 x 122
747 DPM	2	21			-	-	●	-	300	-	
748 DPM	10	100			-	-	●	-	300	-	

Key to options : ● = available    - = not available    ■ = check availability with HNL Technical Sales

**Output Switch**

Output Switch Codes				Availability of Output Switch Codes by Area Classification		
Single Switch	Twin Switch 2 x SPDT	Output Switch Rating	Contact Material	Notes	B	5,6,7
<b>01</b>	–	250/480 Vac 10A, 28 Vdc 4A	Silver	Adjustable differential microswitch ( ≈ 5 to 12% of span)	–	•
<b>13</b>	<b>23</b>	250 Vac 4A, 28 Vdc 2A	Silver	HNL standard low differential microswitches	–	•
<b>14</b>	<b>24</b>	125 Vac 800mA, 28 Vdc 800mA	Gold		–	•
<b>15</b>	<b>25</b>	125 Vac 800mA, 28 Vdc 800mA	Gold	Environment free encapsulated low differential microswitch	•	•
<b>17</b>	<b>27</b>	250 Vac 4A, 28 Vdc 2A	Silver	Environment free encapsulated low differential microswitch	•	•
<b>1A</b>	<b>2A</b>	250 Vac 6A, 28 Vdc 2.5A	Silver	HNL standard encapsulated microswitches	–	•
<b>1B</b>	<b>2B</b>	250 Vac 100mA, 28 Vdc 100mA	Gold		–	•

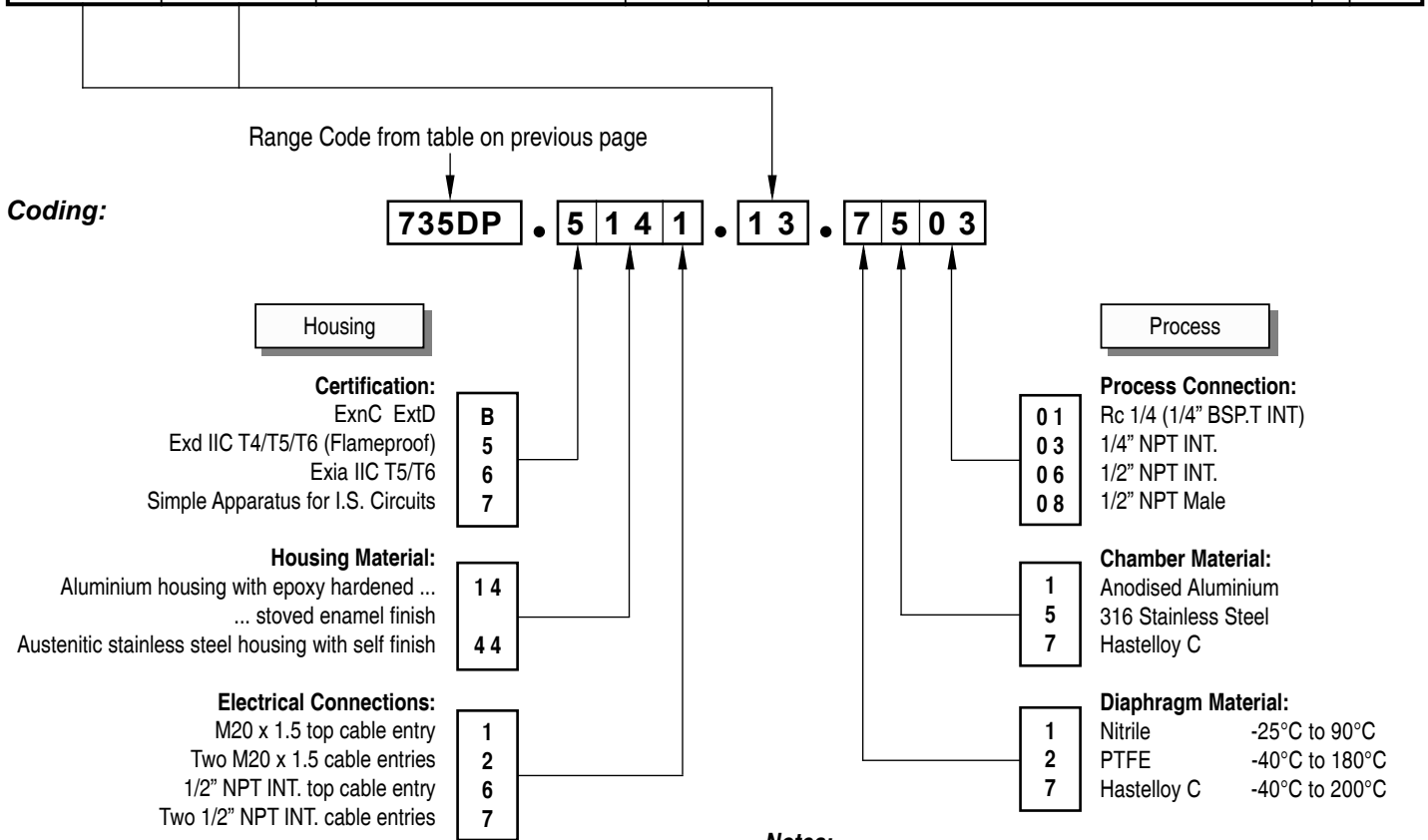

**Notes on Output Switch Selection:**

- Gold contact microswitches are especially well suited for low voltages and currents, or for applications with low switching frequencies or sulphurous atmospheres. When heavier loads need to be switched preference should usually be given to silver contacts.
- The use of twin switches will increase the basic reset by 1%. The combined reset band must not exceed 7%.
- When twin switches are set up to operate as DPDT, simultaneous operation on both rising and falling pressures cannot be guaranteed due to mechanical variations between individual microswitches.
- The use of output switch codes 1A, 2A, 1B and 2B will increase the basic reset by 1%.
- Output switch code 01 cannot be used with an enclosure having two electrical entries.

**Notes:**

- Typical dimensions shown on range table are for a 1/4" internal connection and may increase for alternative connection sizes.
- Dust and weatherproof ratings are IP66 to BS EN 60529 (IEC 60529).
- An 'M' within the range code signifies DP connections suitable for direct mounting of standard equalising manifolds.
- On some ranges 1/2" NPT connections are via a supplied adaptor.
- A 'Z' within the range code signifies at or below zero. This is achieved with the use of a stainless steel biasing assembly within the process chamber. If stainless steel is not compatible with the process an alternative 'X' option is available (e.g. 744PX instead of 744PZ).
- A large number of flanged, chemical seal and alternative threaded connections are available as special options. Please contact HNL Technical Sales for details.

### Scale Accuracy & Setpoint Calibration:

A 0-100 scale is fitted to all switches and provides an approximate indication of the setpoint relative to the range of the switch. The scale is not intended for precise calibration purposes. For precise calibration the scale should be used for initial guidance and the final adjustment made against an instrument sufficiently accurate to meet the site requirements.

### Combined Switching Errors & Maximum Working Pressure (MWP):

In accordance with BS6134 1991:

The sum of the average switching errors and the operating value repeatability will typically not exceed 0.3% of range span, at setpoints of 10%, 50% and 90% of span, at constant calibration and measurement temperatures.

The maximum working pressure of the Series 700 switches is 0.67 x the proof pressure. It should be noted that diaphragm type switches generally have a high overload capability.

### Reset (Switching Differential):

The reset varies throughout the range, normally increasing with setpoint, and the figure quoted in the range table is the switching differential value (as defined in BS6134) expressed as a percentage of the span at the mid range setpoint.

### Ambient Temperature Ratings:

Enclosures are rated for continuous use over the temperature range  $-20^{\circ}\text{C}$  to  $+85^{\circ}\text{C}$ . The use of a high T class will reduce the maximum ambient temperature. At T6 the maximum ambient temperature is  $40^{\circ}\text{C}$  for Exd,  $65^{\circ}\text{C}$  for ExnC and  $75^{\circ}\text{C}$  for Exia.

Storage limits for all enclosures are  $-50^{\circ}\text{C}$  to  $+90^{\circ}\text{C}$ .

Exposure of the enclosure to direct sunlight should be such that the heat gain due to absorption of radiant energy does not cause the enclosure temperature to exceed the recommended maximum. Sufficient signal line cooling must always be provided to ensure that heat conduction from the process will not cause the switch enclosure to operate outside the stated ambient temperature limits.

### Temperature Coefficient:

The additional error, relative to a setpoint calibration of  $20^{\circ}\text{C}$ , will not exceed 0.3% per  $10^{\circ}\text{C}$  change within the normal ambient temperature range of the switch enclosure.

### Process Options:

For switches fitted with metallic diaphragms, a PTFE ring is incorporated on some ranges to provide additional sealing. Should PTFE not be compatible with the process media please contact HNL Technical Sales for advice on alternatives.

### Special Options & Specifications:

For additional Pressure and DP ranges, degreasing of process wetted materials for oxygen service and accessories, refer to data sheet TD OPT. For additional diaphragms, chamber materials and connections, refer to data sheet TD SPO.

### Standards

This product complies with standard EN60947-5-1:2004 in addition to the standards listed for hazardous area certification.

### Specifications

Parameter definitions are in accordance with BS6134:1991 (Pressure and Vacuum Switches).

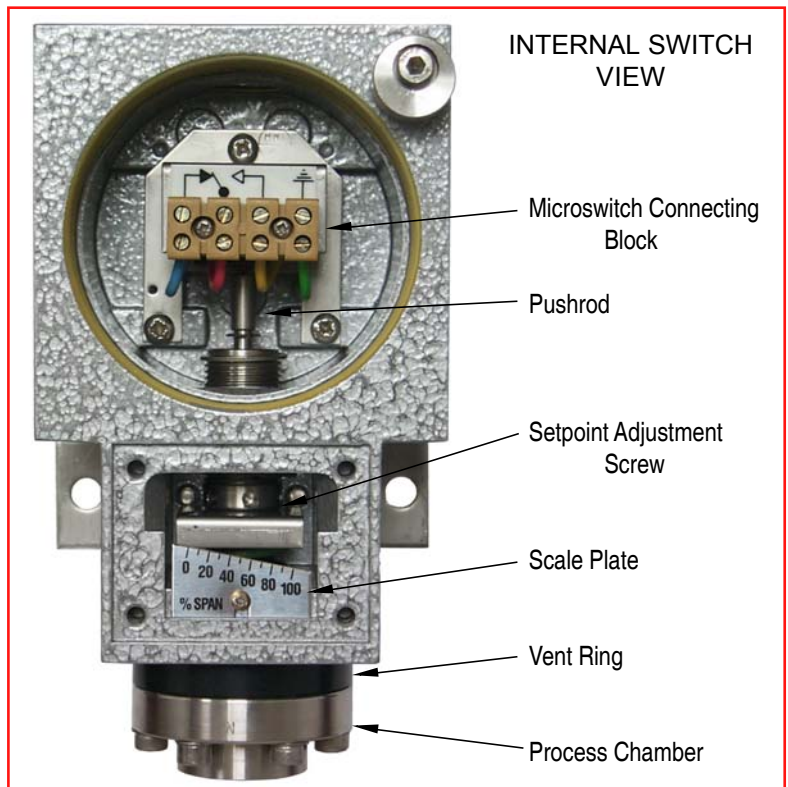

### Instruments & Controls

Pressure, DP and Temperature Switches & Transmitters. Rotary and linear positioners. Flow regulators & Bubblers. Control Systems.

### Precision Machining

Turning, Milling, Drilling, Tapping, Sawing, Welding, Painting, Anodising. From small to large batch sizes in a wide range of materials.

### Manifolds & Valves

Wide range of distribution manifolds in both anodised aluminium and stainless steel. Stainless steel ball valves.

The information contained in this data sheet may be changed without notice.