

# Rosemount 2088 Absolute and Gage Pressure Transmitter

- *Performance of 0.075% with High Accuracy option*
- *Lightweight, compact design for cost effective installation*
- *Protocols available include 4-20 mA HART® and 1-5 Vdc HART Low Power*
- *Absolute and gage pressure ranges up to 4,000 psi (276 bar)*
- *Rangeability of 20:1*



## Contents

Ordering Information . . . . .	page 3
Specifications . . . . .	page 6
Product Certifications . . . . .	page 8
Dimensional Drawings. . . . .	page 11

## Rosemount 2088 Pressure Transmitter Product Offering



### Proven Reliability for Gage and Absolute Applications

- Available protocols include 4-20 mA HART® and 1-5 Vdc HART Low Power
- Fully Configurable LCD to display process variable, percent of range, and diagnostic messages
- Lightweight, compact design enables easy installation
- Choice of Stainless Steel or Alloy C-276 wetted materials



### Unlock the Value of Devices with the Smart Wireless THUM™ Adapter

- Gain access to field intelligence and improve quality, safety, availability, operations, and maintenance costs
- Remotely manage devices and monitor health
- Enable new wireless measurement points
- Utilize existing loop power



### Proven, Reliable, and Innovative DP Level Technologies

- Connect to virtually any process with a comprehensive offering of process connections, fill fluids, direct mount or capillary connections and materials
- Quantify and optimize total system performance with QZ option



### Instrument Manifolds – Quality, Convenient, and Easy

- Designed and engineered for optimal performance with Rosemount transmitters
- Save installation time and money with factory assembly
- Offers a variety of styles, materials, and configurations

## Ordering Information

Table 1. Rosemount 2088 Pressure Transmitter Ordering Information

★ The Standard offering represents the most common options. The starred options (★) should be selected for best delivery.  
The Expanded offering is manufactured after receipt of order and is subject to additional delivery lead time.

Model	Product description			
<b>Standard</b>				<b>Standard</b>
2088	Pressure Transmitter			★
<b>Code</b>	<b>Measurement Type</b>			
<b>Standard</b>				<b>Standard</b>
A	Absolute			★
G	Gage			★
<b>Code</b>	<b>Pressure Ranges</b>			
<b>Standard</b>				<b>Standard</b>
	<b>2088G</b>	<b>2088A</b>		
1	-14.7 to 30 psi / (-1,01 to 2,1 bar)	0 to 30 psi (0 to 2,1 bar)		★
2	-14.7 to 150 psi (-1,01 to 10,3 bar)	0 to 150 psi (0 to 10,3 bar)		★
3	-14.7 to 800 psi (-1,01 to 55,2 bar)	0 to 800 psi (0 to 55,2 bar)		★
4	-14.7 to 4,000 psi (-1,01 to 275,8 bar)	0 to 4,000 psi (0 to 275,8 bar)		★
<b>Code</b>	<b>Transmitter Output</b>			
<b>Standard</b>				<b>Standard</b>
S	4–20 mA dc/Digital HART® Protocol			★
N	1-5 Vdc Low Power/ Digital HART protocol			★
<b>Code</b>	<b>Materials of Construction</b>			
<b>Standard</b>				<b>Standard</b>
	<b>Process connection</b>	<b>Isolating diaphragm</b>	<b>Fill Fluid</b>	
22 <sup>(1)</sup>	316L SST	316L SST	Silicone	★
33 <sup>(1)</sup>	Alloy C-276	Alloy C-276	Silicone	★
<b>Expanded</b>				
2B <sup>(1)</sup>	316L SST	316L SST	Inert	
<b>Code</b>	<b>Process Connection</b>			
<b>Standard</b>				<b>Standard</b>
A	½–14 NPT Female			★
B <sup>(2)</sup>	DIN 16288 G ½ Male			★
<b>Expanded</b>				
C <sup>(2)(3)</sup>	RC ½ Female (PT ½ Female)			
<b>Standard</b>				<b>Standard</b>
D <sup>(2)(3)</sup>	M20 × 1.5 Male (CM20 Male)			★
<b>Code</b>	<b>Conduit Entry</b>			
<b>Standard</b>				<b>Standard</b>
1	½–14 NPT			★
2 <sup>(2)</sup>	M20 × 1.5 Female			★
<b>Expanded</b>				
4 <sup>(2)</sup>	G ½ Female (PF ½ Female)			

# Rosemount 2088

Table 1. Rosemount 2088 Pressure Transmitter Ordering Information

★ The Standard offering represents the most common options. The starred options (★) should be selected for best delivery.  
The Expanded offering is manufactured after receipt of order and is subject to additional delivery lead time.

## Options (Include with selected model number)

<b>Diaphragm seal assemblies</b>		
<b>Standard</b>		<b>Standard</b>
S1 <sup>(4)(5)</sup>	Assemble to one Rosemount 1199 diaphragm seal	★
<b>Display and Interface</b>		
<b>Standard</b>		<b>Standard</b>
M5	LCD display	★
M7	LCD display, special configuration	★
<b>Mounting brackets</b>		
<b>Standard</b>		<b>Standard</b>
B4	SST mounting bracket with SST Bolts	★
<b>Product Certifications</b>		
<b>Standard</b>		<b>Standard</b>
C6	CSA Explosion-Proof, Intrinsically Safe, and non-Incendive	★
E2	INMETRO Flameproof	★
E4 <sup>(2)(6)</sup>	TIIS Flameproof	★
E5	FM Explosion-Proof, Dust Ignition-proof	★
E7	IECEX Flameproof	★
ED	ATEX Flameproof	★
I1 <sup>(2)</sup>	ATEX Intrinsic Safety	★
I2	INMETRO Intrinsic Safety	★
I5	FM Intrinsically safe, Division 2	★
I7	SAA Intrinsic Safety	★
K1	ATEX Flameproof, Intrinsic Safety, Type n, Dust	★
K5	FM Explosion-Proof, Dust Ignition-proof, Intrinsically Safe, Division 2	★
K6 <sup>(2)</sup>	CSA Explosion-Proof, Dust Ignition-proof, Intrinsically Safe, Division 2	★
K7	SAA Intrinsic Safety and Type n; IECEX Flameproof and Dust	★
KB	FM and CSA Explosion-Proof, Dust Ignition-proof, Intrinsically Safe, Division 2	★
KH <sup>(2)</sup>	FM Approvals and ATEX Explosion-Proof and Intrinsically Safe	★
N1 <sup>(2)</sup>	ATEX Type n	★
N7	SAA Type n	★
ND <sup>(2)</sup>	ATEX Dust	★
NK	IECEX Dust	★
<b>Shipboard Approvals</b>		
<b>Standard</b>		<b>Standard</b>
SBS	American Bureau of Shipping	★
<b>Pressure Testing</b>		
<b>Expanded</b>		
P1	Hydrostatic testing	
<b>Terminal Blocks</b>		
<b>Standard</b>		<b>Standard</b>
T1	Transient protection	★
<b>Special Cleaning</b>		
<b>Expanded</b>		
P2	Cleaning for special service	
<b>Calibration Certificate</b>		
<b>Standard</b>		<b>Standard</b>
Q4	Calibration certificate	★

Table 1. Rosemount 2088 Pressure Transmitter Ordering Information

★ The Standard offering represents the most common options. The starred options (★) should be selected for best delivery. The Expanded offering is manufactured after receipt of order and is subject to additional delivery lead time.

<b>Quality Calibration Certificate Traceability Certification</b>		
<b>Standard</b>		<b>Standard</b>
Q8	Material Traceability Certification per EN 10204 3.1B	★
<b>Digital Signal</b>		
<b>Standard</b>		<b>Standard</b>
C4 <sup>(2)</sup>	NAMUR alarm and saturation levels, high alarm	★
CN <sup>(2)</sup>	NAMUR alarm and saturation levels, low alarm	★
<b>Configuration</b>		
<b>Standard</b>		<b>Standard</b>
C9	Software configuration	★
<b>Manifold Assemblies</b>		
<b>Standard</b>		<b>Standard</b>
S5 <sup>(4)(5)</sup>	Assemble to Rosemount 306 integral manifold	★
<b>Calibration Accuracy</b>		
<b>Standard</b>		<b>Standard</b>
P8 <sup>(7)</sup>	0.075% accuracy to 10:1 turndown	★
<b>Water Approval</b>		
<b>Standard</b>		<b>Standard</b>
DW <sup>(8)</sup>	NSF drinking water approval	★
<b>Low Output for Low Power</b>		
<b>Expanded</b>		
C2	0.8 - 3.2 Vdc output with HART protocol	
<b>Surface Finish</b>		
<b>Standard</b>		<b>Standard</b>
Q16	Surface finish certification for sanitary remote seals	★
<b>Toolkit Total System Performance Reports</b>		
<b>Standard</b>		<b>Standard</b>
QZ	Remote Seal System Performance Calculation Report	★
<b>Typical Model Number: 2088 G 2 S 22 A 1 B4 M5</b>		

- (1) Materials of Construction comply with recommendations per NACE MR0175/ISO 15156 for sour oil field production environments. Environmental limits apply to certain materials. Consult latest standard for details. Selected materials also conform to NACE MR0103 for sour refining environments.
- (2) Not available with low-power Output code N.
- (3) Not available with Alloy C-276, Materials of Construction code 33.
- (4) Use 1/2 - 14 NPT Female Process Connection code A.
- (5) "Assemble-to" items are specified separately and require a completed model number.
- (6) Only available with Conduit Thread code 4.
- (7) Available with Output code S, stainless steel isolators, and silicone fill.
- (8) Requires Materials of Construction code 22 with Process Connection code A.

# Specifications

## Performance Specifications

(Zero-based spans, reference conditions, silicone oil fill, and 316L SST isolating diaphragm.)

### Reference Accuracy

- ±0.10% of calibrated span. Includes combined effects of linearity, hysteresis, and repeatability
- ±0.075% of calibrated span (high accuracy option)

### Ambient Temperature Effect

Expressed as a total effect per 50 °F (28 °C)

Total effect includes zero and span effects.

± (0.15% URL + 0.15% of span) from -40 °F to 185 °F (-40 °C to 85 °C)

### Stability

±0.10% of URL for 12 months

### Vibration Effect

Less than ±0.1% of URL when subjected to vibration of: peak to peak constant displacement of 4 mm (5–15 Hz) and constant acceleration of 2 g (15–150 Hz) and 1 g (150–2000 Hz).

### Power Supply Effect

Less than 0.01% of calibrated span per volt

### Mounting Position Effect

Zero shift of up to 1.2 inH<sub>2</sub>O (0.30 kPa), which can be calibrated out. No span effect.

### RFI Effect

Less than ±0.25% of upper range limit from 20–1000 MHz at 30 V/m with leads in conduit. Less than ±0.25% of upper range limit from 20–1000 MHz at 10 V/m with unshielded twisted pair (no conduit).

### Transient Protection Limits

#### IEEE 587 Category B

- 6 kV Crest (1.2 × 50 μs)
- 3 kA Crest (8 × 20 μs)
- 6 kV Crest (0.5 μs by 100 kHz)

#### IEEE 472

SWC 2.5 kV Crest, 1 MHz waveform

### General Specifications

Tested to IEC 801-3

## Functional Specifications

### Service

Liquid, gas, and vapor applications

## Ranges

Range	Minimum Span	Upper (URL)	Lower (LRL)	Lower <sup>(1)</sup> (LRL) (Gage)
1	1.5 psi (0,103 bar)	30 psi (2,1 bar)	0 psia (0 bar)	-14.7 psig (-1,01 bar)
2	8 psi (0,55 bar)	150 psi (10,3 bar)	0 psia (0 bar)	-14.7 psig (-1,01 bar)
3	40 psi (2,76 bar)	800 psi (55,2 bar)	0 psia (0 bar)	-14.7 psig (-1,01 bar)
4	200 psi (13,8 bar)	4000 psi (275,8 bar)	0 psia (0 bar)	-14.7 psig (-1,01 bar)

(1) Assumes atmospheric pressure of 14.7 psig.

## Output

Code S: 4–20 mA dc

Code N: 1-5 volt dc, low power

(Outputs are directly proportional to the input pressure)

## Rangedown

20 to 1

## Load Limitations

Reverse polarity protection is standard. Maximum loop resistance is determined by the power supply voltage as described by the following equations:

$$\text{Max. Loop Resistance} = 43.5 (\text{Power Supply Voltage} - 10.5)$$

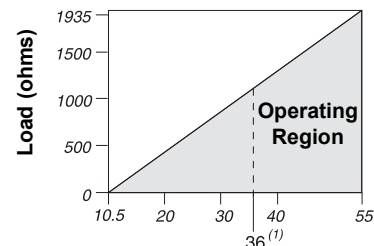

Power Supply Output Code S (dc Volts)

Communication requires a minimum loop resistance of 250 ohms.

(1) For hazardous location approvals, power supply must not exceed 36 V.

(2) For CENELEC Ex ia approval, the power supply must not exceed 30 V.

## Power Supply

External power supply required. Transmitter operates on 10.5–36 Vdc with no load (6–14 V for Low Power). Reverse polarity protection is standard.

## Current Draw

Output Code N: ≤ 3 mA without LCD display.

## Overpressure Limits

Range 1: 120 psig max

All other ranges: two times the URL

**Burst Pressure**

11,000 psi for all ranges

**Zero Elevation and Suppression**

Zero can be suppressed between atmosphere for gage transmitters or 0 psia for absolute transmitters and upper range limit, provided the calibrated span is equal to or greater than the minimum span, and the upper range value does not exceed the upper range limit.

**Time Response**

Time Constant: 200 milliseconds  
Dead time: < 0.1 s  
Update rate: 20 times per second minimum

**Temperature Limits**

Ambient:  
-40 to 185 °F (-40 to 85 °C)  
-4 to 175 °F (-20 to 80 °C) with LCD display<sup>(1)</sup>  
*(1) LCD display may not be readable and LCD updates will be slower at temperatures below -4 °F (-20 °C).*

Storage:  
-50 to 230 °F (-46 to 110 °C)  
-40 to 185 °F (-40 to 85 °C) with LCD display

Process:  
Silicone fill sensor: -40 to 250 °F (-40 to 121 °C)<sup>(1)</sup>  
Inert fill sensor: -22 to 250 °F (-30 to 121 °C)<sup>(1)</sup>  
Process temperatures above 185 °F (85 °C) require derating the ambient limits by a 1.5:1 ratio. For example, for process temperature of 195 °F (91 °C), new ambient temperature limit is equal to 170 °F (77 °C). This can be determined as follows:  
(195 °F - 185 °F) x 1.5 = 15 °F, 185 °F - 15 °F = 170 °F  
*(1) 250 °F (140 °C) limit in vacuum service; 130 °F (54 °C) for pressures below 0.5 psia.*

**Humidity Limits**  
0-100% relative humidity

**Volumetric Displacement**  
Less than 0.00042 cm<sup>3</sup>

**Turn-on Time**  
2.0 seconds, no warm-up required

**Transmitter Security**  
Activating the transmitter security function prevents changes to the transmitter configuration, including local zero and span adjustments. Security is activated by an internal switch.

**Failure Mode**  
If self-diagnostics detect a sensor or microprocessor failure, the analog signal is driven either high or low to alert the user. High or low failure mode is user-selectable with a jumper on the transmitter. The values to which the transmitter drives its output in failure mode depend on whether it is factory-configured to *standard* or *NAMUR-compliant* operation. The values for each are as follows:

Standard Operation			
Output Code	Linear Output	Fail High	Fail Low
S	$3.9 \leq I \leq 20.8$	$I \geq 21.75 \text{ mA}$	$I \leq 3.75 \text{ mA}$
N	$0.97 \leq V \leq 5.2$	$V \geq 5.4 \text{ V}$	$V \leq 0.95 \text{ V}$
N with Code C2	$0.78 \leq V \leq 3.44$	$V \geq 4.0 \text{ V}$	$V \leq 0.77 \text{ V}$

NAMUR-Compliant Operation			
Output Code	Linear Output	Fail High	Fail Low
Output Code S	$3.8 \leq I \leq 20.5$	$I \geq 22.5 \text{ mA}$	$I \leq 3.6 \text{ mA}$

**Physical Specifications**

**Electrical Connection**  
<sup>1</sup>/<sub>2</sub>-14 NPT, M20 x 1.5 (CM20), PG 13.5, or G <sup>1</sup>/<sub>2</sub> female (PF <sup>1</sup>/<sub>2</sub> female) conduit entry

**Process Connection**  
<sup>1</sup>/<sub>2</sub>-14 NPT female, DIN 16288 G <sup>1</sup>/<sub>2</sub> male, RC <sup>1</sup>/<sub>2</sub> female (PT <sup>1</sup>/<sub>2</sub> female), M20 x 1.5 (CM20) male

**Process Wetted Parts**  
**Isolating Diaphragm**  
316L stainless steel or Alloy C-276

**Process Connector**  
316L stainless steel CF-3M (Cast version of 316L SST, material per ASTM\_A743) or Alloy C-276

**Non-wetted Parts**  
**Electronics Housing**  
Low-copper aluminum, NEMA 4X, IP65, IP67, CSA enclosure Type 4X

**Paint**  
Polyurethane

**Cover O-rings**  
Buna-N

**Fill Fluid**  
Silicone or inert fill

**Weight**  
Output Code S and N: Approximately 2.44 lb (1.11 kg)

**Tagging**  
The transmitter is tagged, at no charge, in accordance with customer requirements. All tags are stainless steel. The standard tag is permanently attached to the transmitter. Tag character height is <sup>1</sup>/<sub>8</sub> in. (0.318 cm). A wired tag is available upon request.

**Accessory Block and Bleed Valve (S5 Option)**  
The Rosemount 306 Integral Manifold is pre-assembled to transmitter and leak checked.

## Product Certifications

### Approved Manufacturing Locations

Rosemount Inc. — Chanhassen, Minnesota, USA  
Emerson Process Management GmbH & Co. — Wessling, Germany  
Emerson Process Management Asia Pacific Private Limited — Singapore  
Beijing Rosemount Far East Instrument Co., LTD — Beijing, China

### European Directive Information

The EC declaration of conformity can be found at [www.rosemount.com](http://www.rosemount.com).

#### ATEX Directive (94/9/EC)

Emerson Process Management complies with the ATEX Directive.

#### European Pressure Equipment Directive (PED) (97/23/EC)

2088/2090 Pressure Transmitters  
— Sound Engineering Practice

#### Electro Magnetic Compatibility (EMC) (2004/108/EC)

All Model 2088/2090 Pressure Transmitter:  
EN 61326-1:2006

### Hazardous Locations Certifications

#### North American Certifications

##### Ordinary Location Certification for Factory Mutual

As standard, the transmitter has been examined and tested to determine that the design meets basic electrical, mechanical, and fire protection requirements by FM, a nationally recognized testing laboratory (NRTL) as accredited by the Federal Occupational Safety and Health Administration (OSHA).

##### Factory Mutual (FM) Approvals

- E5** Explosion-Proof for Class I, Division 1, Groups B, C, and D. Dust-Ignition-Proof for Class II, Division 1, Groups E, F, G, Class III, Division 1, indoor and outdoor (NEMA 4X) hazardous locations; factory sealed. Temperature Class T5 Ta = 85 °C.
- I5** Intrinsically safe for use in Class I, Division 1, Groups A, B, C, D; Class II, Division 1, Groups E, F, and G; and Class III, Division 1 when connected in accordance with Rosemount drawing 02088-1018. Non-incendive for Class I, Division 2, Groups A, B, C, and D.  
For input parameters see control drawing 02088-1018. Temperature Class T4 Ta = 85 °C; indoor and outdoor (NEMA 4X) hazardous locations.

#### Canadian Standards Association (CSA)

All CSA hazardous approved transmitters are certified per ANSI/ISA 12.27.01-2003.

- C6** Explosion-Proof for Class I, Division 1, Groups B, C, and D. Dust-Ignition-Proof for Class II, Division 1, Groups E, F, G, Class III, indoor and outdoor hazardous locations. CSA enclosure Type 4X; factory sealed. Suitable for Class I, Division 2, Groups A, B, C, and D. 2088 is Single Seal. Intrinsically Safe for Class I, Division 1, Groups A, B, C, and D. Temp. Code T3C. Intrinsically safe when connected with approved barriers in accordance with Rosemount drawing 02088-1024. 2088 is Single Seal.  
For input parameters see control drawing 02088-1024.

### European Certifications



- I1** BASEEFA ATEX Intrinsic Safety  
Certificate No.: BAS00ATEX1166X  II 1 G  
Ex ia IIC T5 (-55 °C ≤ T<sub>amb</sub> ≤ 40 °C)  
Ex ia IIC T4 (-55 °C ≤ T<sub>amb</sub> ≤ 70 °C)  
**CE** 1180

Table 2. Input Parameters

Loop/Power
U <sub>i</sub> = 30 Vdc
I <sub>i</sub> = 200 mA
P <sub>i</sub> = 0.9 W
C <sub>i</sub> = 0.012 μF

#### Special Conditions For Safe Use (x):

When the optional transient protection terminal block is installed, the apparatus is not capable of withstanding a 500 V root-mean-square test to case. This must be taken into account on any installation in which it is used, for example by assuring that the supply to the apparatus is galvanically isolated.

- N1** BASEEFA ATEX Type n  
Certification No.: BAS00ATEX3167X  II 3 G  
Ex nA nL IIC T5 (-40 °C ≤ T<sub>amb</sub> ≤ 70 °C)  
U<sub>i</sub> = 50 Vdc max  
**CE**

#### Special Conditions For Safe Use (x):

When the optional transient protection terminal block is installed, the apparatus is not capable of withstanding a 500 V root-mean-square test to case. This must be taken into account on any installation in which it is used, for example, by assuring that the supply to the apparatus is galvanically isolated.



# Product Data Sheet

00813-0100-4690, Rev LA

October 2010

# Rosemount 2088

**ND** BASEEFA ATEX Dust  
 Certificate No.: BAS01ATEX1427X  II 1 D  
 Ex tD A20 T105 °C (−20 °C ≤ T<sub>amb</sub> ≤ 85 °C)  
 IP66  
 CE 1180  
 V<sub>max</sub> = 36 V<sub>dc</sub>

**Special Conditions For Safe Use (x):**

1. The user must ensure that the maximum rated voltage and current (36 volts, 24 mA, D.C.) are not exceeded. All connections to other apparatus or associated apparatus shall have control over this voltage and current equivalent to a category “ib” circuit according to EN50020.
2. Cable entries must be used which maintain the ingress protection of the enclosure to at least IP66.
3. Unused cable entries must be filled with suitable blanking plugs which maintain the ingress protection of the enclosure to at least IP66.
4. Cable entries and blanking plugs must be suitable for the ambient range of the apparatus and capable of withstanding a 7J impact test.
5. The 2088/2090 sensor module must be securely screwed in place to maintain the ingress protection of the enclosure.

**ED** KEMA ATEX Flameproof  
 Certification No.: KEMA97ATEX2378  II 1/2 G  
 Ex d IIC T6 (−40 °C ≤ T<sub>amb</sub> ≤ 40 °C)  
 T4 (−40 °C ≤ T<sub>amb</sub> ≤ 40 °C)  
 CE 1180  
 V<sub>max</sub> = 36 (with Output Code S)  
 V<sub>max</sub> = 14 (with Output Code N)

**Special Conditions for Safe Use (x):**

1. The cable and conduit entry devices shall be of a certified flameproof type Ex d, suitable for the conditions of use and correctly installed.
2. With the use of conduit entries a sealing device shall be provided immediately on the entrance thereto.
3. Unused apertures shall be closed with suitable Ex d certified blanking elements.
4. Suitable heat-resisting cables shall be used when the ambient temperature at the cable or conduit entries exceed 65 °C.
5. This device contains a thin wall diaphragm. Installation, maintenance, and use shall take into account the environmental conditions to which the diaphragm will be subjected. The manufacturer's instructions for installation and maintenance shall be followed in detail to assure safety during its expected lifetime.
6. For information on the dimensions of the flameproof joints the manufacturer shall be contacted.

## Japanese Certifications

**E4** TIIS Flameproof  
 Ex d IIC T6 (T<sub>amb</sub> = 85 °C)

Certificate	Description
TC15874	2088 with Alloy C-276 wetted parts (with display)
TC15873	2088 with Alloy C-276 wetted parts (no display)
TC15872	2088 with SST wetted parts (with display)
TC15871	2088 with SST wetted parts (no display)

## Australian Certifications

**I7** SAA Intrinsic Safety  
 Certification No.: AUS Ex 1249X  
 Ex ia IIC T4 (T<sub>amb</sub> = 70 °C)  
 Ex ia IIC T5 (T<sub>amb</sub> = 40 °C)  
 IP66  
 When connected per Rosemount drawing 03031-1026

Table 3. Input Parameters

Loop/Power
U <sub>max</sub> = 30 V
I <sub>max</sub> = 200 mA
P <sub>max</sub> = 0.9 W
C <sub>i</sub> = 0.01 μF
L <sub>i</sub> = 10 μH

**Special Conditions For Safe Use (X):**

Observe barrier/entity parameters during installation. A passive current limited power source must be used. The power source must be such that  $P_o \leq (U_o * I_o)/4$ . For modules using transient protection in the terminal assembly (T1 transient protection models), the apparatus enclosure is to be electrically bonded to the protective earth. The conductor used for the connection shall be equivalent to a copper conductor of 4 mm<sup>2</sup> minimum cross-sectional area.

**N7** SAA Type n (Non-Sparking)  
 Certificate No.: AUS Ex 1249X  
 Ex n IIC T4 (T<sub>amb</sub> = 70 °C)  
 Ex n IIC T5 (T<sub>amb</sub> = 40 °C)  
 IP66

**Special Conditions For Safe Use (X):**

Where the equipment is installed such that there is an unused conduit entry, it must be sealed with a suitable blanking plug to maintain the IP66 degree of protection. Any blanking plug used with the equipment shall be of a type which requires the use of a tool to affect its removal. Voltage source shall not exceed 60 Vac or 75 Vdc.

# Rosemount 2088

## E7 KEMA IECEx Flameproof

Certification No.: IECEx KEM 06.0021X

Ex d IIC T4 ( $-40\text{ °C} \leq T_{\text{amb}} \leq 80\text{ °C}$ )

CE 1180

Vmax = 36 (with Output Code S)

Vmax = 14 (with Output Code N)

## NK IECEx Dust Ignition Proof

IECEx Certificate number: IECEx KEM 06.0021X

Ex tD A22 IP66 T90 °C ( $T_{\text{amb}} = -20\text{ °C}$  to  $80\text{ °C}$ )

Vmax = 55 Vdc

Ii = 23 mA

### Special Conditions For Safe Use (x):

1. The device contains a thin wall diaphragm. Installation, maintenance, and use shall take into account the environmental conditions to which the diaphragm will be subjected. The manufacturer's instructions for installation and maintenance shall be followed in detail to assure safety during its expected lifetime.
2. Cable entries must be used which maintain the ingress protection of the enclosure to at least IP 66.
3. Unused cable entries must be used which maintain the ingress protection of the enclosure to at least IP 66.
4. Cable entries and blanking plugs must be suitable for the ambient range of the apparatus and capable of withstanding a 7J impact.
5. The 2088/2090 sensor module must be securely screwed in place to maintain the ingress protection of the enclosure

## Brazil Certifications

### I2 INMETRO Intrinsic Safety

Certification No.: CEPEL-Ex-063/97-1X

BR-Ex ia IIC T5/T4

### Special Conditions For Safe Use (x):

Only the sensor piezo-resistive can be installed in Zone 0.  
The transmitter must be installed in Zone 1 or 2.

### E2 INMETRO Flameproof

Certification No.: CEPEL-Ex-076/97-1

BR-Ex d IIC T6/T5

## China Certifications

### I3 China (NEPSI) Intrinsic Safety

Ex ia IIC T4

### E3 China (NEPSI) Flameproof

Ex d IIB + H2 T4/T5

## Combinations of Certifications

Stainless steel certification tag is provided when optional approval is specified. Once a device labeled with multiple approval types is installed, it should not be reinstalled using any other approval types. Permanently mark the approval label to distinguish it from unused approval types.

**KB** Combination of K5 and C6

**KH** Combination of K5, I1, and ED

**K5** Combination of E5 and I5

**K6** Combination of C6, I1, and ED

**K7** Combination of I7, N7, E7, and NK

**K1** Combination of I1, N1, ED, and ND

**Dimensional Drawings**

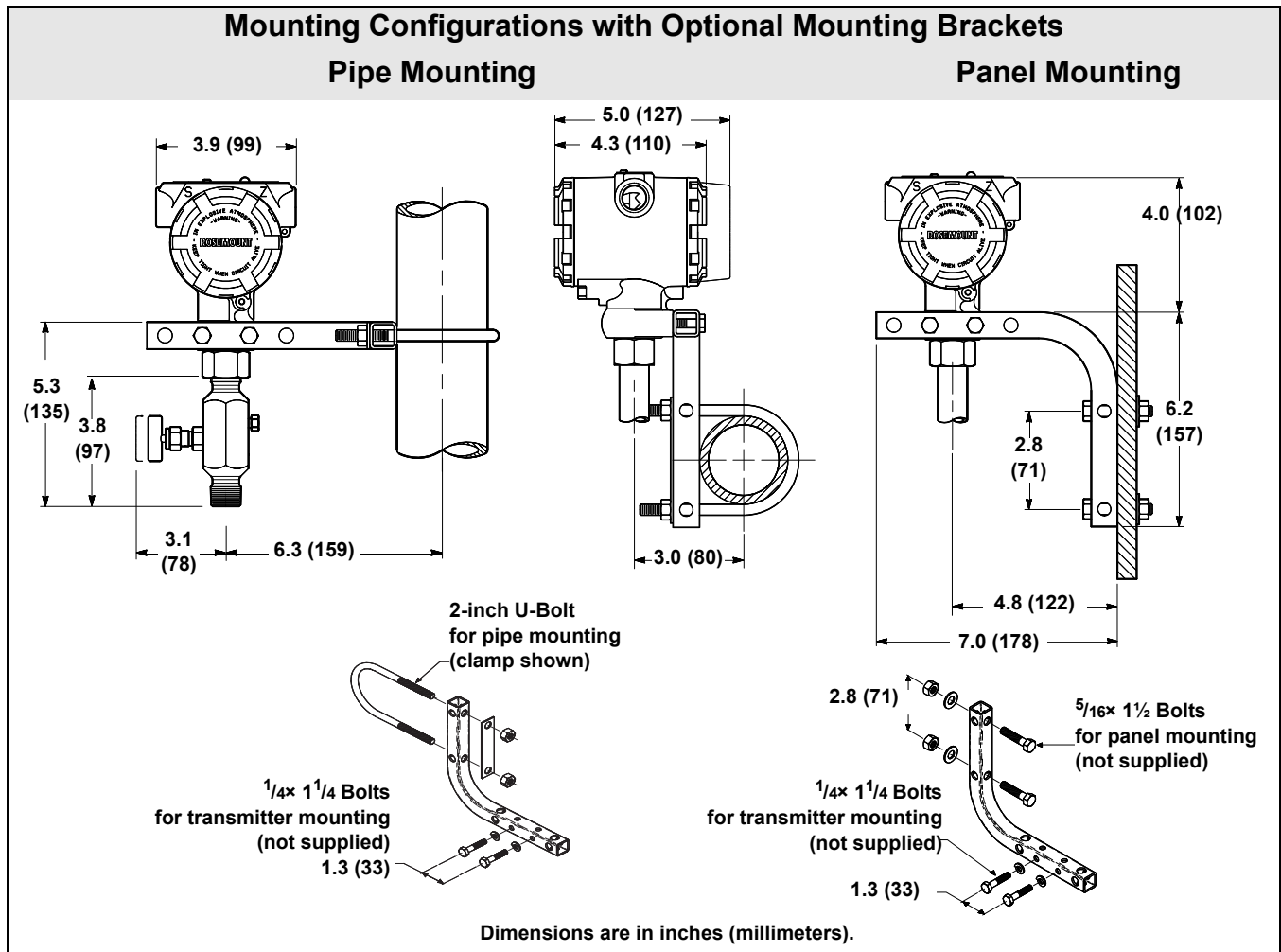
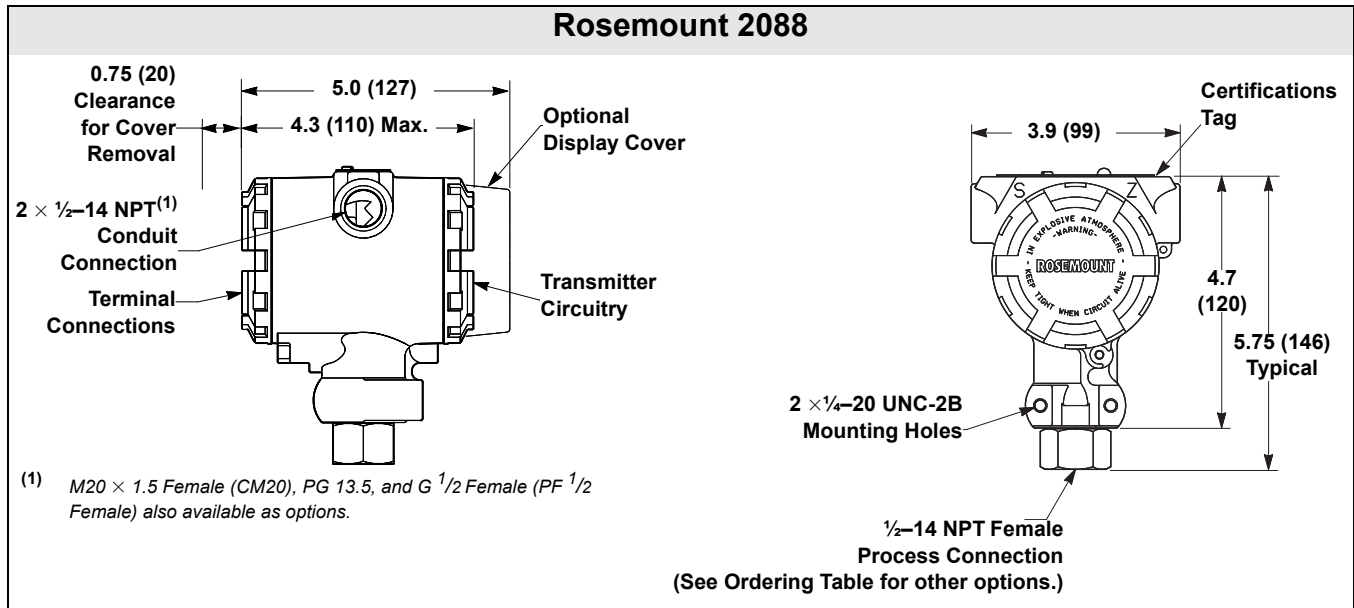

*Standard Terms and Conditions of Sale can be found at [www.rosemount.com/terms\\_of\\_sale](http://www.rosemount.com/terms_of_sale)  
The Emerson logo is a trade mark and service mark of Emerson Electric Co.  
Rosemount, the Rosemount logotype, Annubar, ProPlate and Mass ProPlate are registered trademarks of Rosemount Inc.  
HART is a registered trademark of the HART Communications Foundation.  
PlantWeb is a registered trademark of one of the Emerson Process Management group of companies.  
All other marks are the property of their respective owners.*

© 2010 Rosemount, Inc. All rights reserved.

**Emerson Process Management  
Rosemount Measurement**  
8200 Market Boulevard  
Chanhassen MN 55317 USA  
Tel (USA) 1 800 999 9307  
Tel (International) +1 952 906 8888  
Fax +1 952 949 7001

**Emerson Process Management**  
Blegistrasse 23  
P.O. Box 1046  
CH 6341 Baar  
Switzerland  
Tel +41 (0) 41 768 6111  
Fax +41 (0) 41 768 6300

**Emerson FZE**  
P.O. Box 17033  
Jebel Ali Free Zone  
Dubai UAE  
Tel +971 4 811 8100  
Fax +971 4 886 5465

**Emerson Process Management Asia Pacific  
Pte Ltd**  
1 Pandan Crescent  
Singapore 128461  
Tel +65 6777 8211  
Fax +65 6777 0947  
Service Support Hotline : +65 6770 8711  
Email : [Enquiries@AP.EmersonProcess.com](mailto:Enquiries@AP.EmersonProcess.com)